

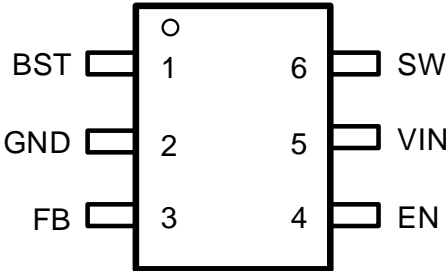

| | | | | | |
|--|--|--|--|--|--|
| | | | | | |
| | | | | | |

| | | | |
|--|--|--|--|
| | | | |
| | | | |



| | | | | |
|--|--|--|--|--|
| | | | | |
| | | | | |
| | | | | |
| | | | | |

| | | | | |
|--|--|--|--|--|
| | | | | |
| | | | | |
| | | | | |

(1)
(2)

| | | | |
|--|--|--|--|
| | | | |
| | | | |
| | | | |
| | | | |
| | | | |
| | | | |

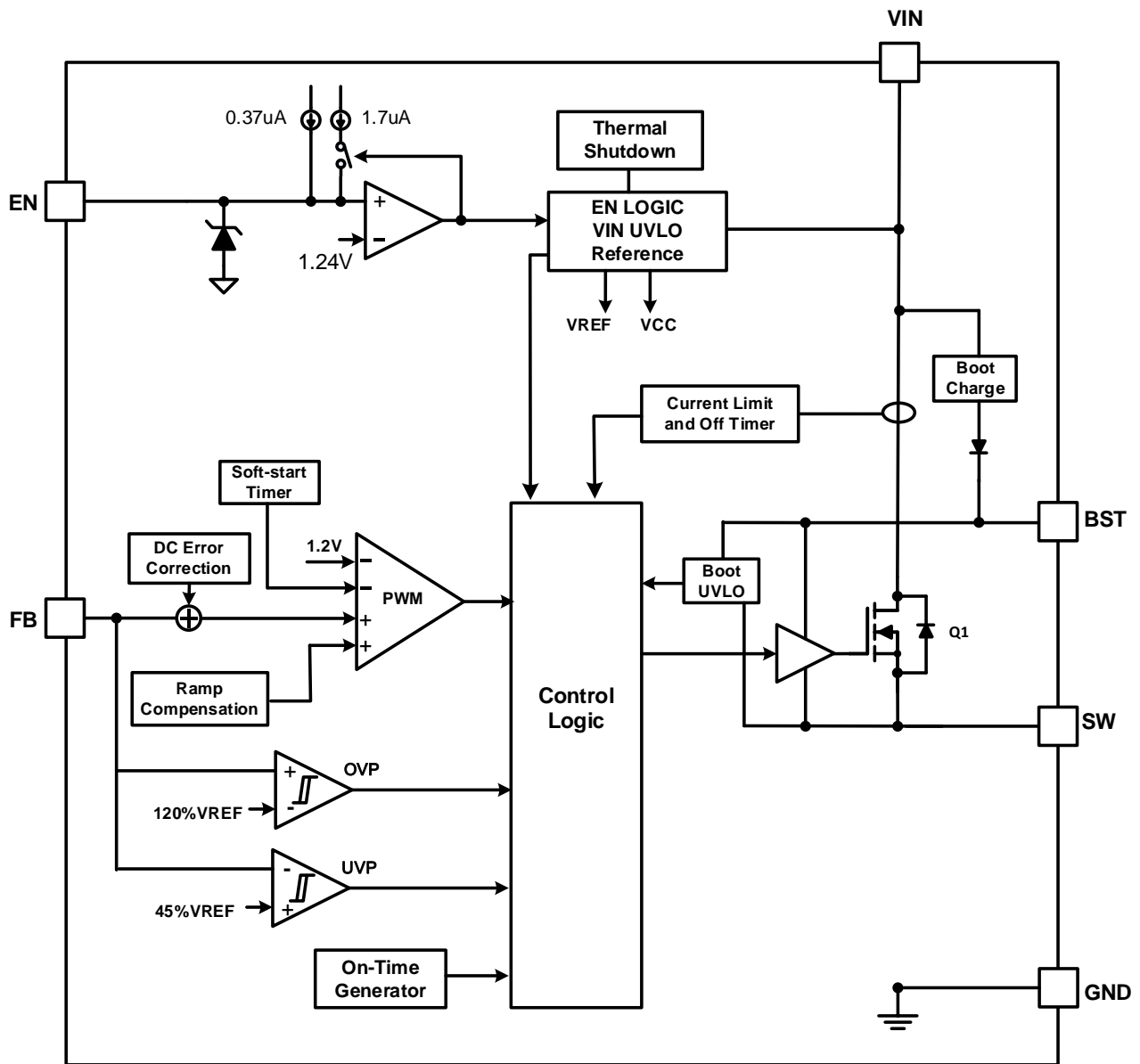

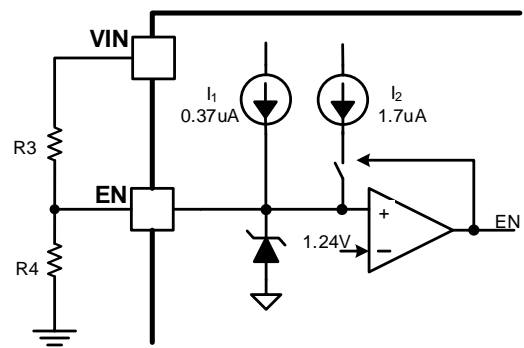

-
-

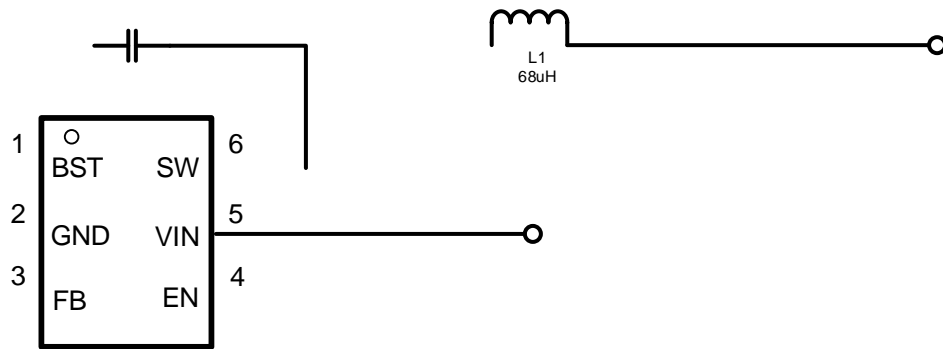

| | |
|--|--|
| | |
| | |
| | |
| | |
| | |
| | |
| | |
| | |
| | |

Table 1. R_1 , R_2 Value for Common Output Voltage
(Room Temperature)

| | | |
|--|--|--|
| | | |
| | | |
| | | |
| | | |
| | | |



-
-





-
-
-
-
-
-

| | | | | | |
|------|----|------|----|----|----|
| Vout | L1 | COUT | R1 | R2 | C7 |
|------|----|------|----|----|----|



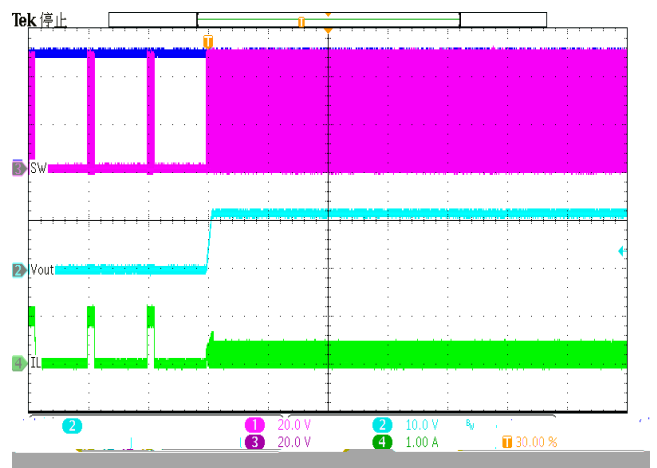
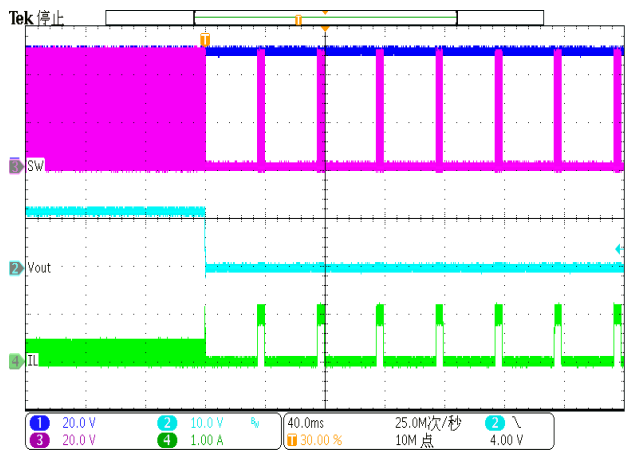
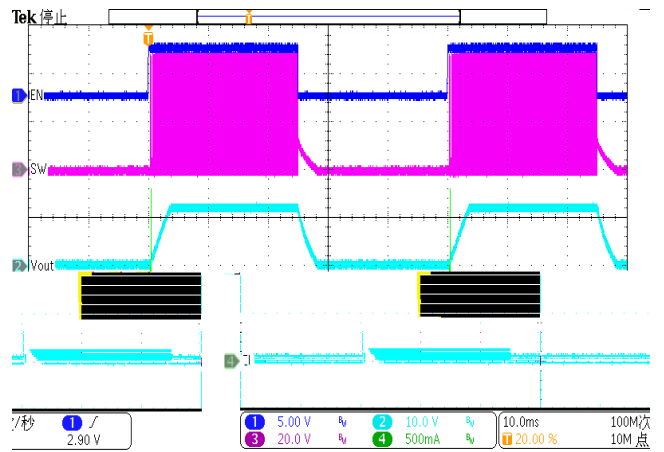
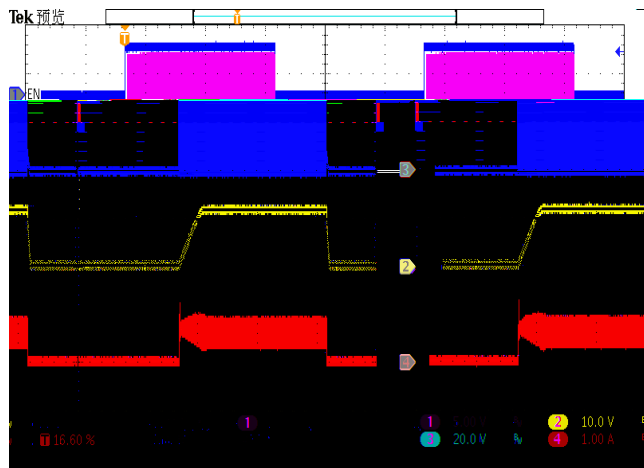
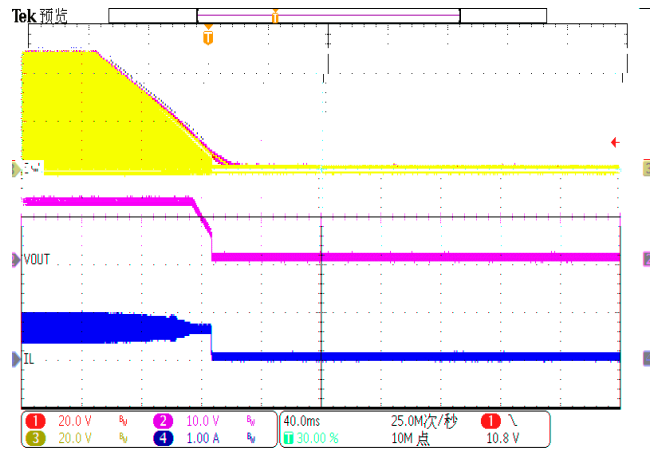
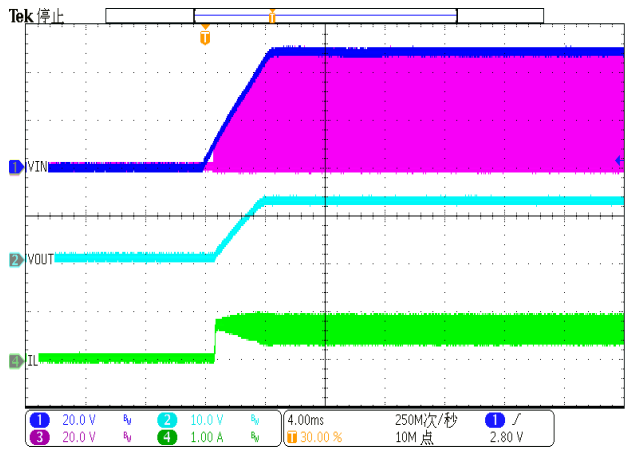

1.

2.

3.

4. M

B

B
H

I
1

LP

5.

6.

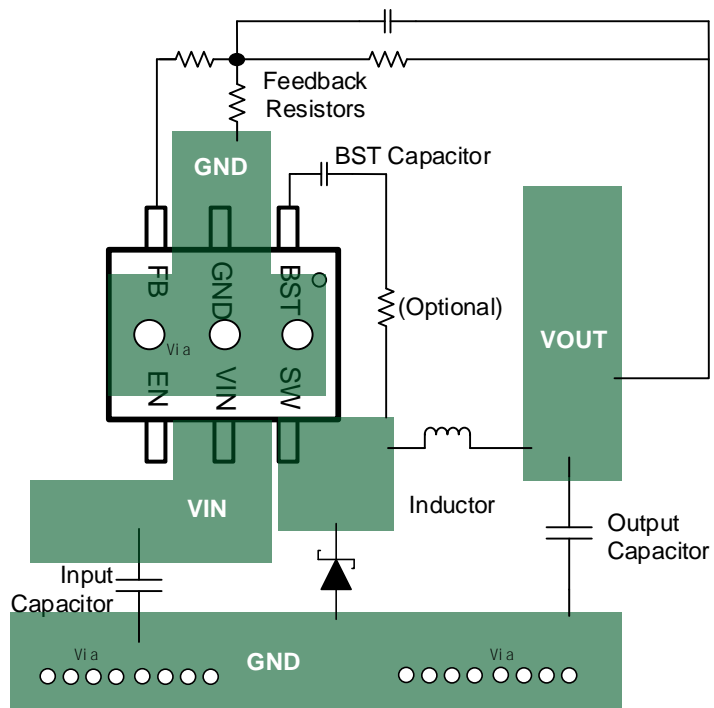

PACKAGE CHEMICAL DRAWING FOR SGT0401

1. Dimensions are in millimeters.

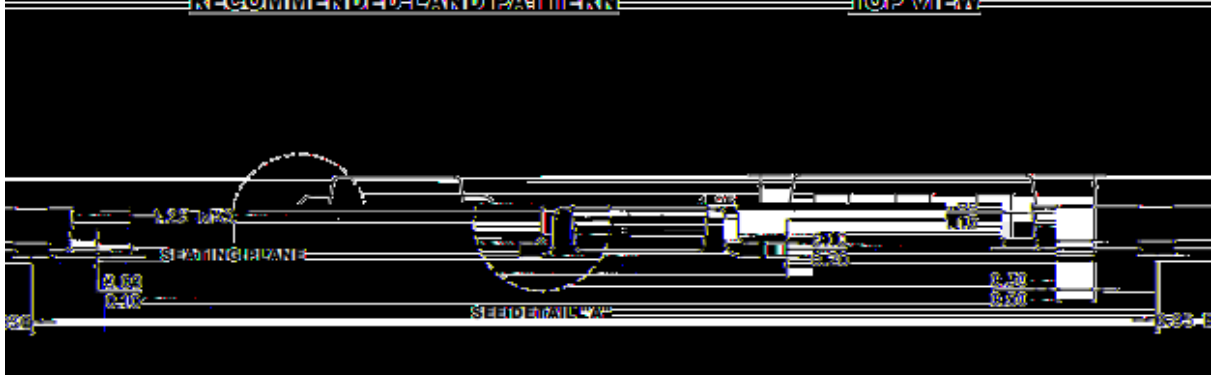
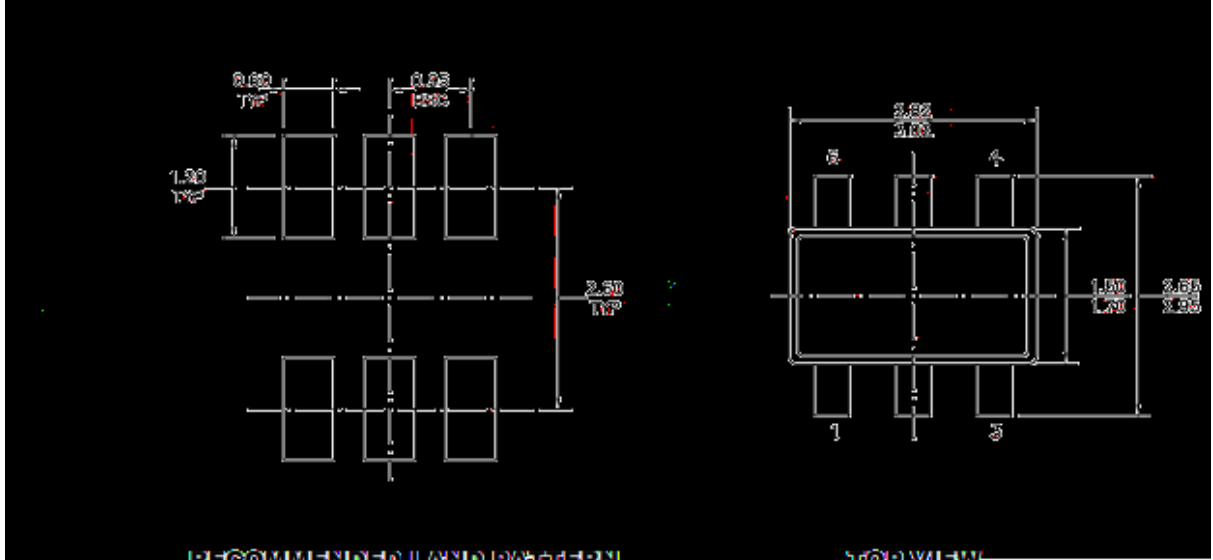

2. Dimensions are in millimeters.

3. PACKAGE LENGTH DOES NOT INCLUDE MOLD

4. DIMENSIONS ARE TO CENTER

5. DIMENSIONS TO CENTER OF PAD

6. DIMENSIONS TO CENTER OF PAD

7. DIMENSIONS TO CENTER OF PAD

8. DIMENSIONS TO CENTER OF PAD

9. DIMENSIONS TO CENTER OF PAD

10. DIMENSIONS TO CENTER OF PAD

11. DIMENSIONS TO CENTER OF PAD

12. DIMENSIONS TO CENTER OF PAD

13. DIMENSIONS TO CENTER OF PAD

14. DIMENSIONS TO CENTER OF PAD

15. DIMENSIONS TO CENTER OF PAD

16. DIMENSIONS TO CENTER OF PAD

17. DIMENSIONS TO CENTER OF PAD

18. DIMENSIONS TO CENTER OF PAD

19. DIMENSIONS TO CENTER OF PAD

20. DIMENSIONS TO CENTER OF PAD

