

?

?

?

---

□ **B**

□



□

**A**

□

□

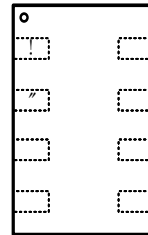
			o
			o



---

?

?

?

?

?





---

2B

?

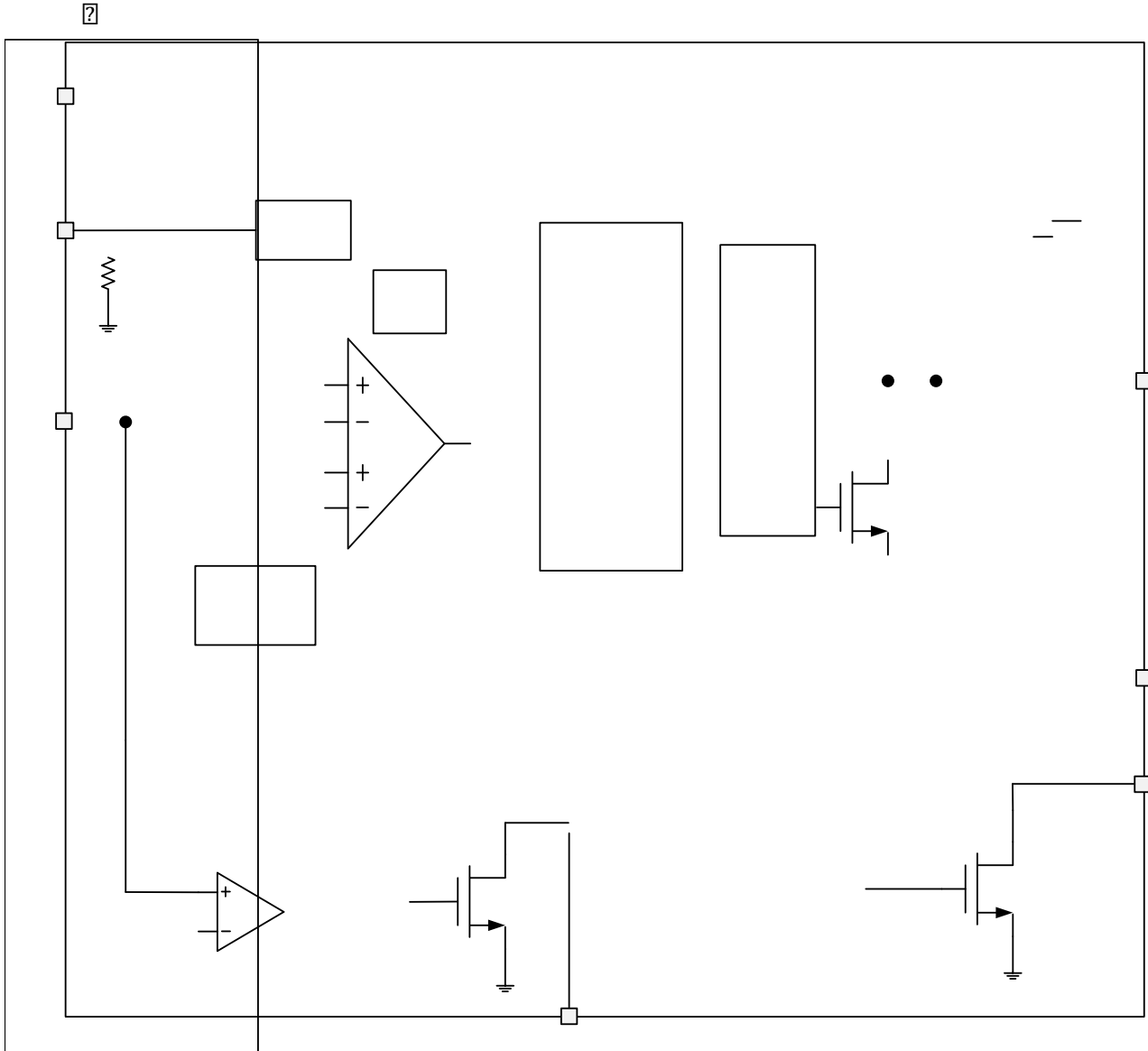
?



---

2





?

?

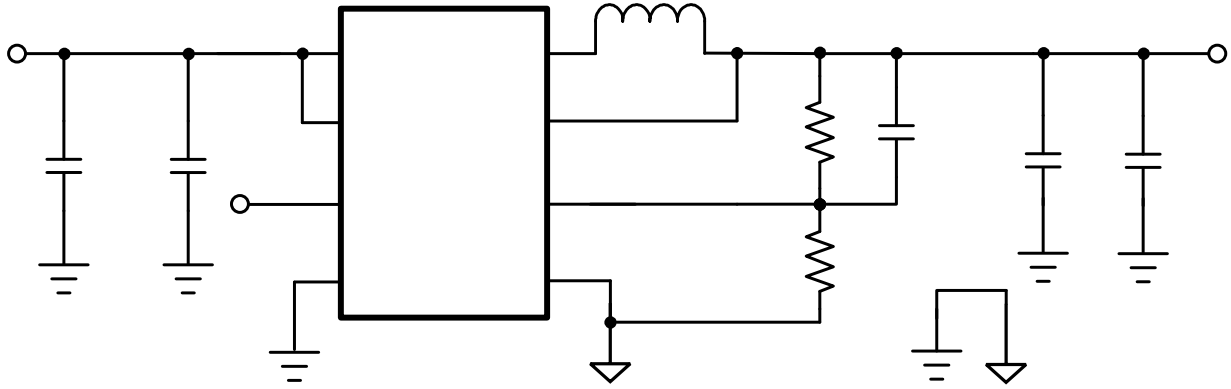





---

$$\sqrt{\frac{( )^2}{2} + \frac{1}{12} ( )^2}$$

2.00888 Tc[(to )] TJ ET Q EMC /Span <</MCID 122/Lang (en-US)>> BDC q 0.00000e W\* n192 0 G -0.00T

$$\sqrt{— (1 —)}$$

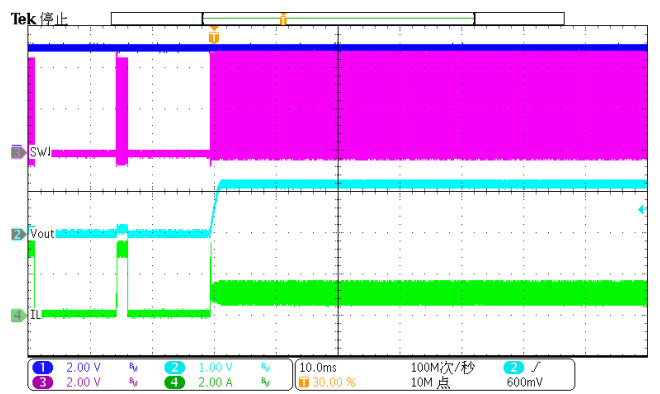
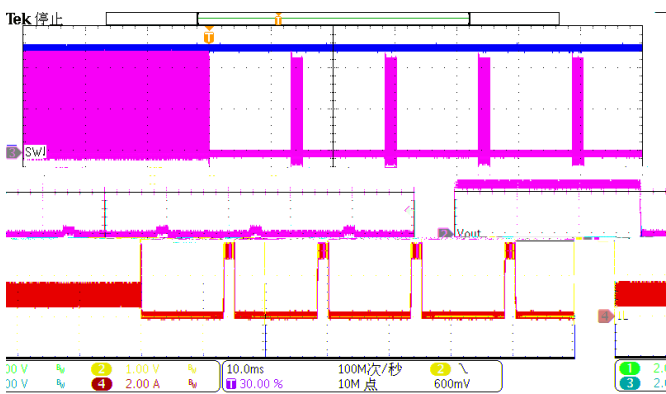
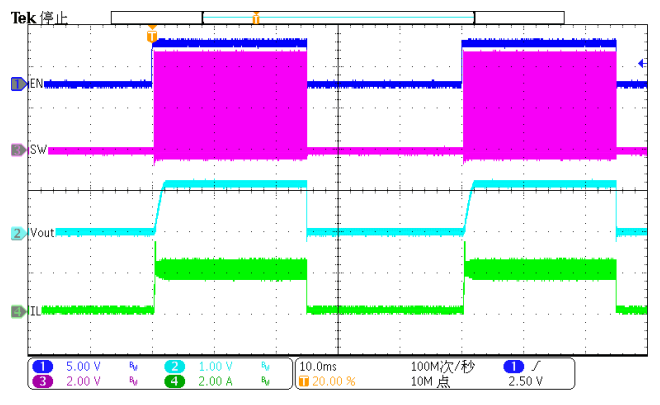
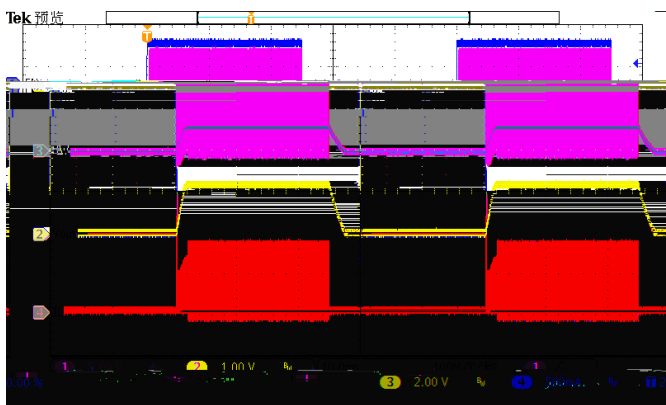
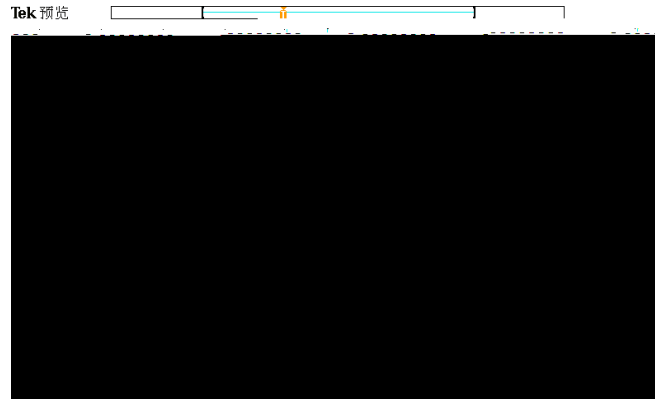
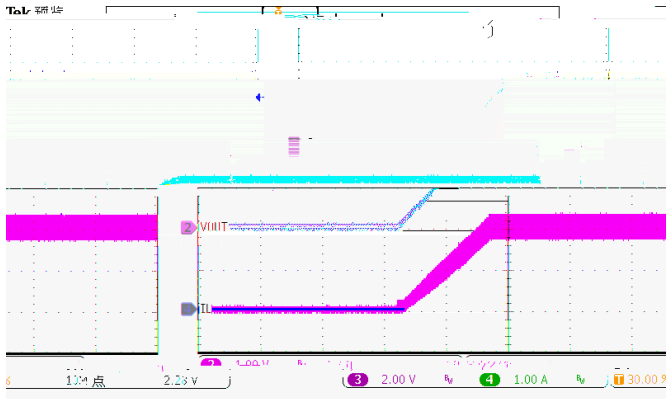



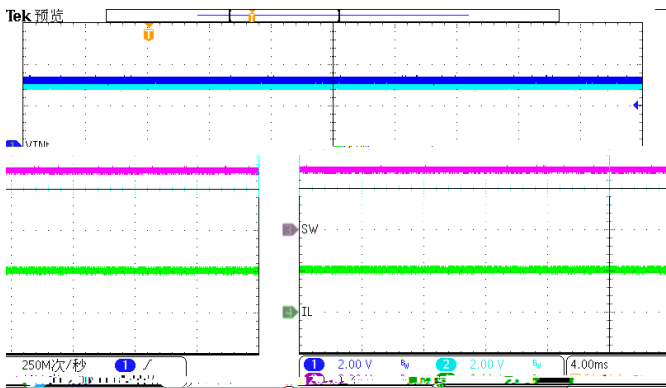
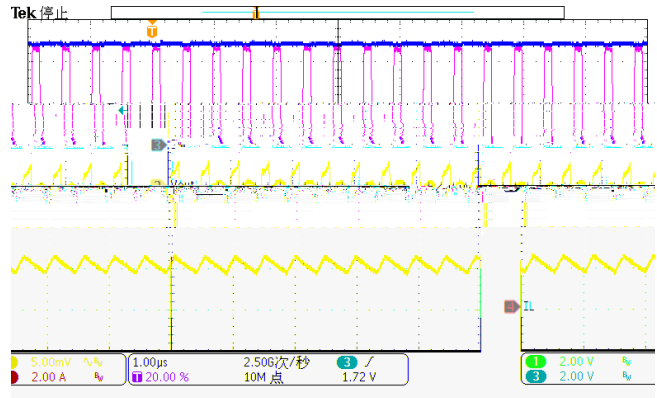
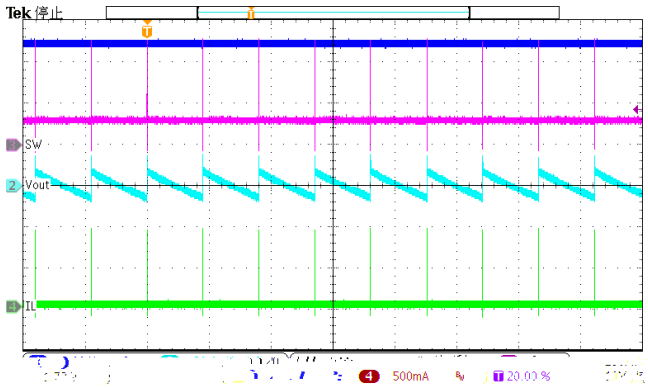
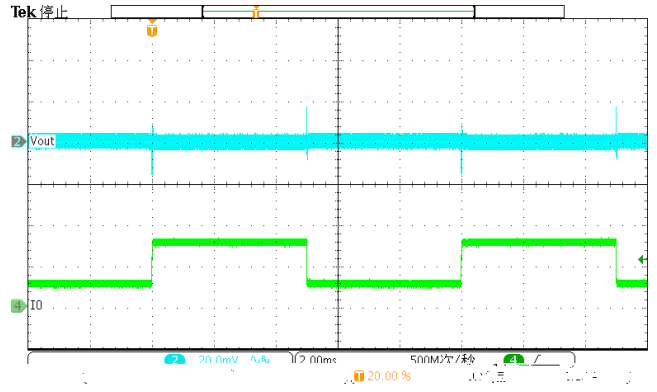
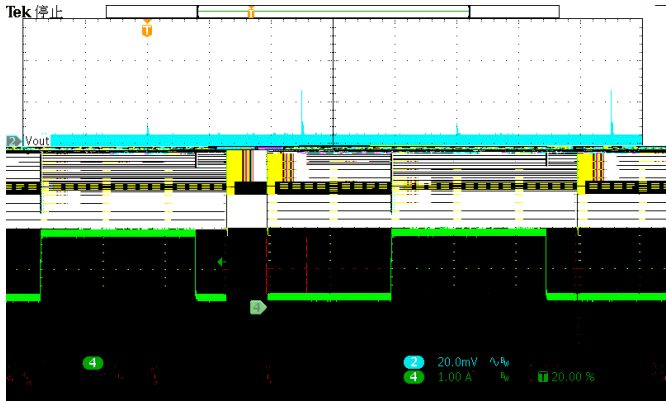



2

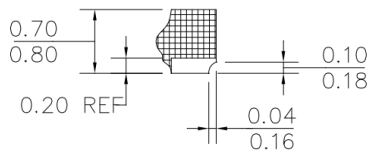
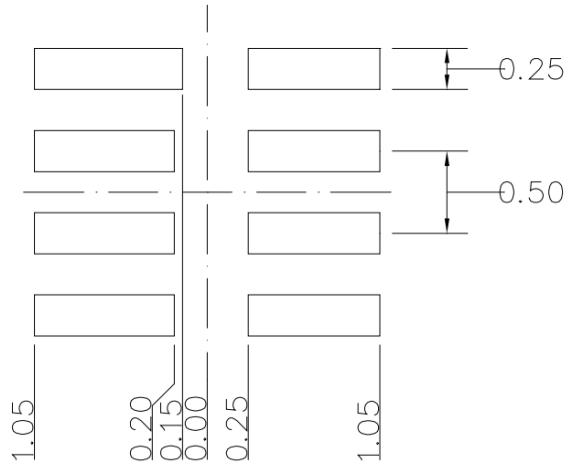
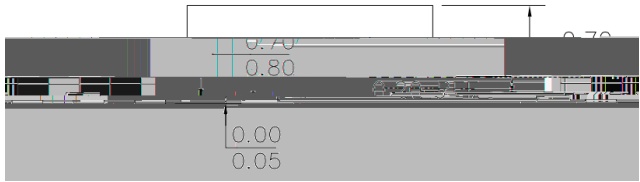
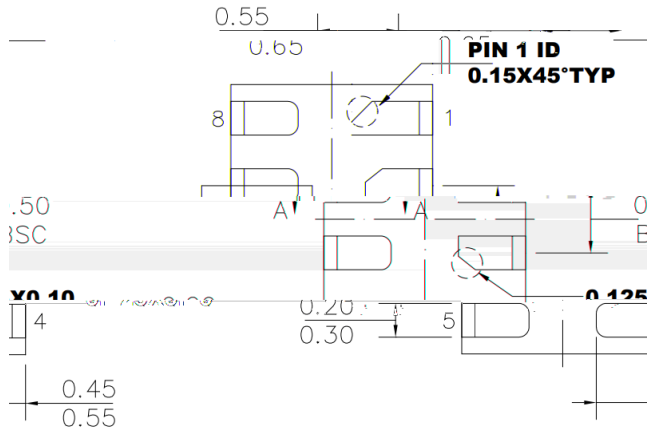
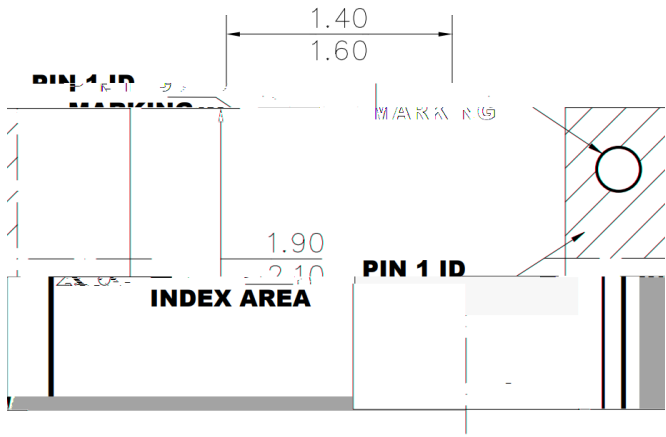

2

2

