

SCT CONFIDENT

SCT CON



SCT CONFIDE

4.4', 4.4', 4 4 4				
4,	-			4
.4',	-			4
4', 34*-	4', 34*- 2 &	4',		4
4 . 34*-	4 . 34*- 2 &	4 .		4
'1& ,	1 4',	, 4 4', * - 4		
'1& , .4',	1 .4', .4',	, 4 .4', 4		
'4, /	/ 4',	, 4 * -		
' .4', /	/ .4', .4',	, 4 * -		
4 , &				4
4 , *				4
0 , .	,			+
4'&	.5 + .5 + *	4 . 4 4 4		4
4**	.5 + .5 + *	4 . 4 4 4		4
0	.5 + 0			
2	+			
2	+			
0 1-, / /	& +- 1 2 / /	4 ₁₂ 4 ₁₅ 4 4 ₁₂ 4 ₁₅ 4		
0 1-, / /	* +- 1 2 / /	4 4		
'**+	&			

SCT CONFIDENTIAL

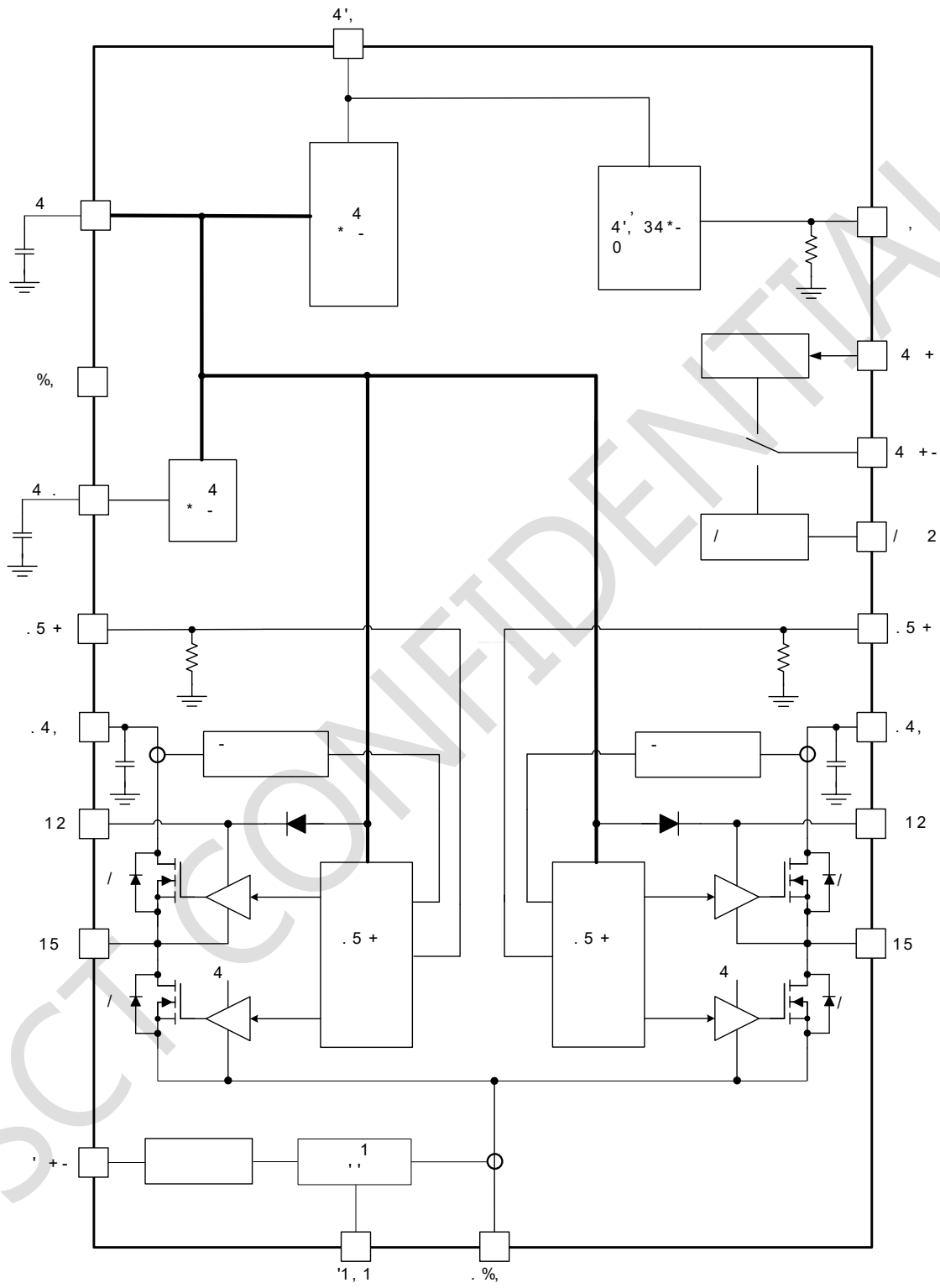

2 1 2
 * - 2
 + 3
 2 1 2
 4', . 4', . 4',
 4', . 4', . 4',
 2 . 5 +
 4' - 1 2
 2 , +- 1 2
 , +- 1 2
 2 1 2
 4', 4
 * - +- 1 2
 5 +- 1 2
 4 . 5 +
 +- 1 2 . 4 , / 4 . 5 +
 4 4 * -
 2 1 2
 4 4 2 2 * - 4',
 , 4
 2 1 2 +- 1 2
 5 .)&)&)& * 2
)&)&)&

SCT CONFIDENTIAL

4 4

2 1 2
* -

* ' / + -

, / 4 4

2 1 2

, /

15
4

/ 4 2

2 1 2

*

4 +-
.5 + .5 + 3

/ 15 /

- 2
- 4 2 & % &
- 4 2 & * - 5

4 +-
4

2 1 2

2

2

2

4 +-

+ 3

4 +

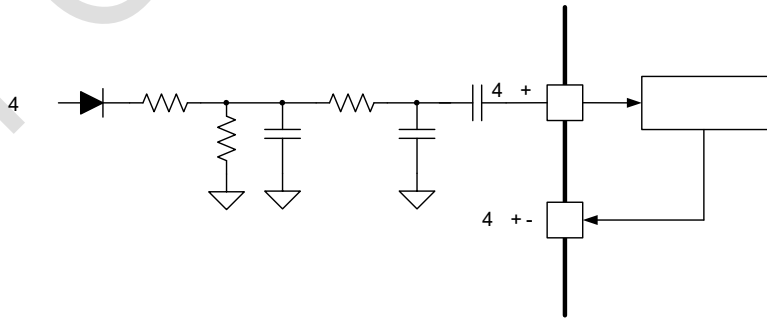

2

'1, 1 2 + 3

4 +- ' +-

2 1 2
-
5

+ - 1 2

SCT CONFIDENTIAL

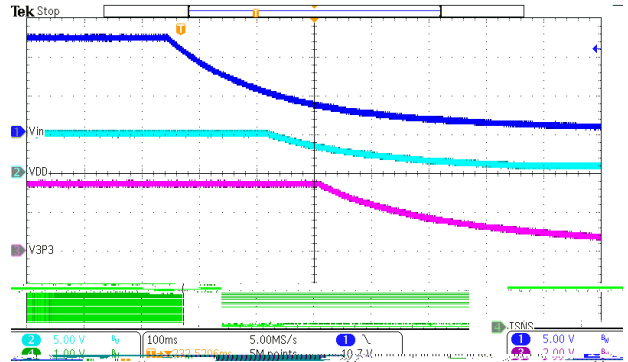
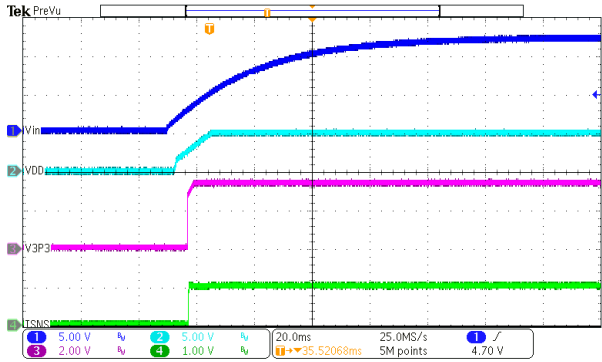

3

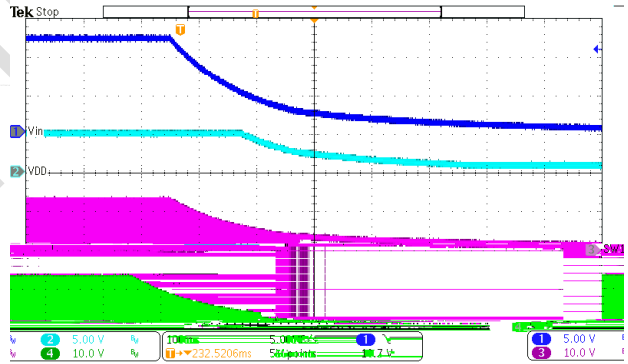
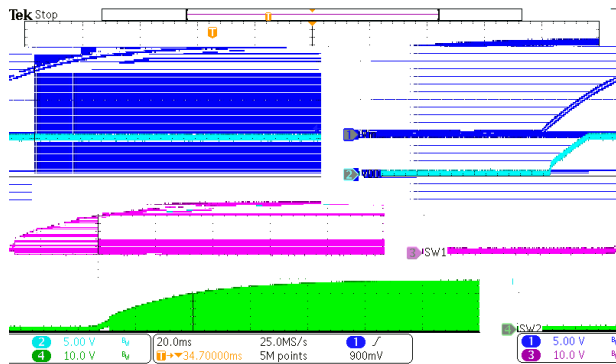

3

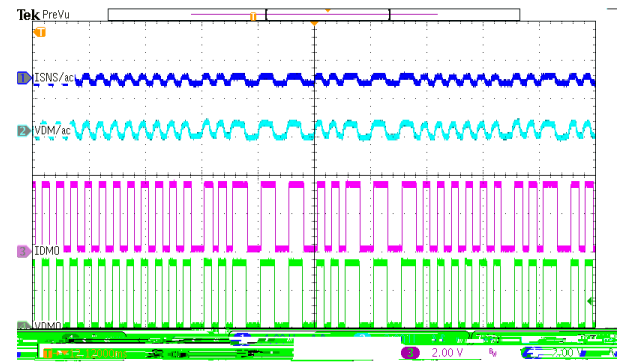
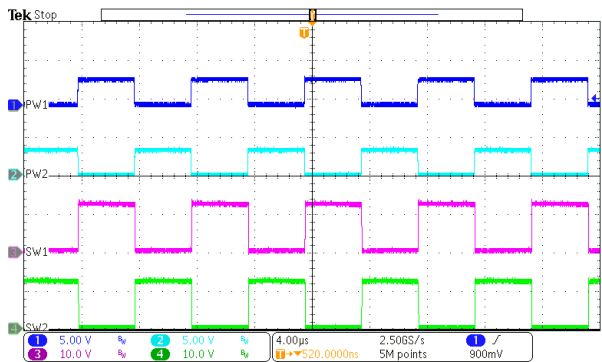

4 4 0 5

4 + - ' + - -

1 2

. 4', . %,

. 4', . %,

. %,

4', %,

4', %,

4

4

4

4

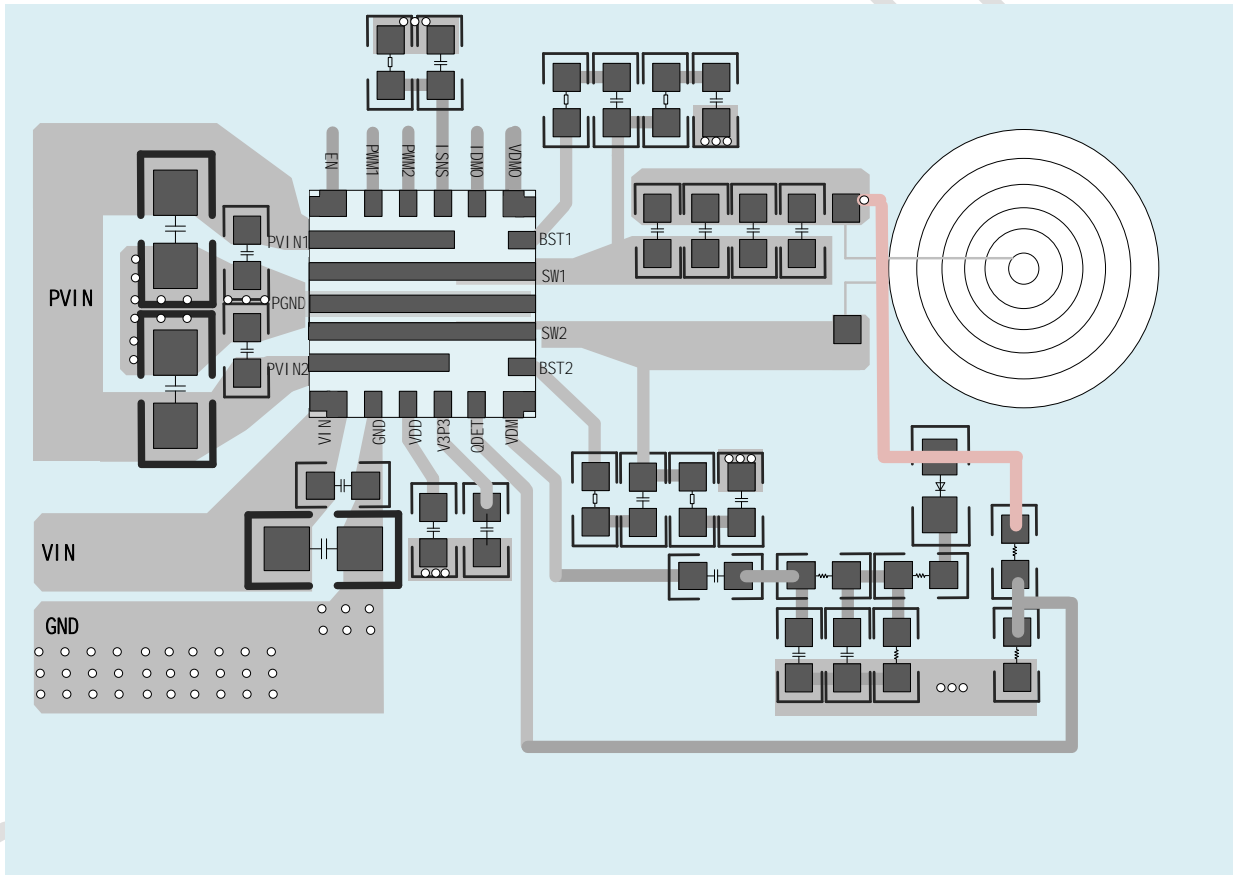

*

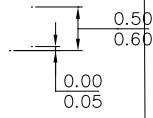
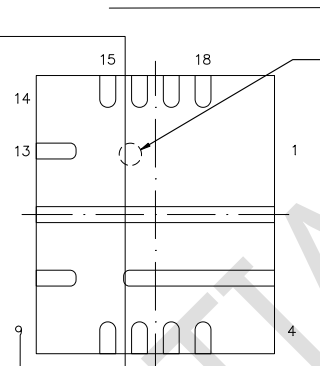
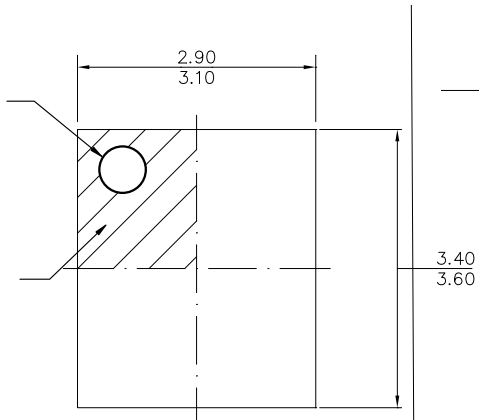

SCT CONFIDENTIAL

SCT CONFID